

O-CXM-XYZXX-X-X-XX-X

Precision Ultra Low Phase Noise OCXO in 36x27 mm “Europack” with optional Adapter to 2”x2”

Product Data Sheet

Description

O-CX...Series is based on Ultra Low Noise 10 MHz reference OCXO and low noise analog multiplier to achieve higher frequencies multiple of 10 MHz

Features

- SC-cut crystal
- High Stability
- Ultra Low Aging
- Ultra Low Phase Noise
- Sine Wave or HCMOS/TTL output

Applications

- Instrumentation
- Telecommunication Systems
- Data Communications
- GPS
- COTS/Dual use

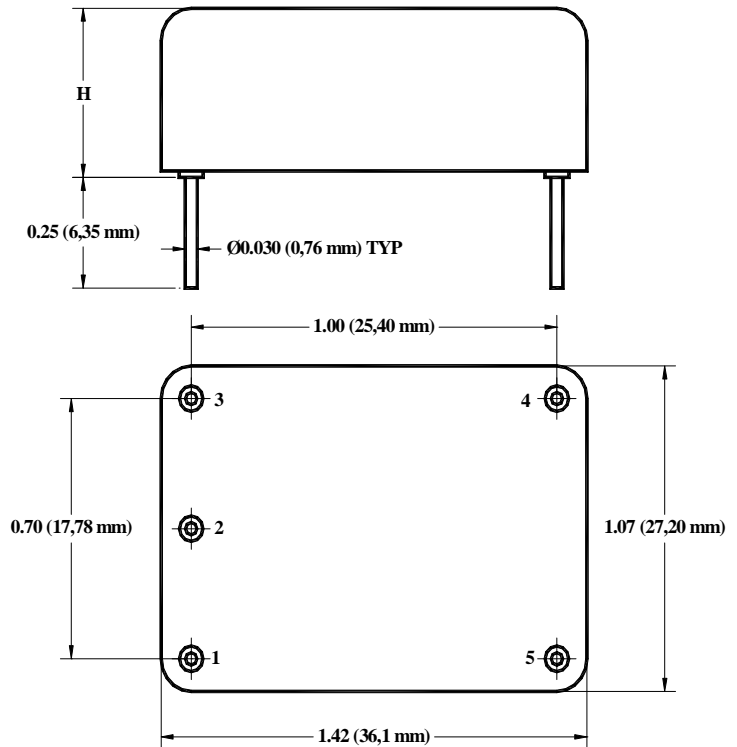

Height H is 0.75” TYP – standard.
For special requirements 0.63” TYP height can be considered – consult factory

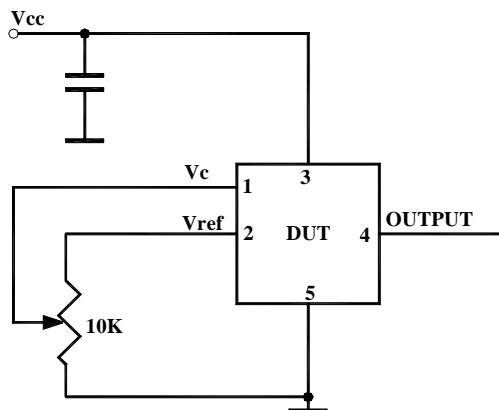

Parameter	Symb	Condition	Min	Typ	Max	Unit	Note
Absolute Maximum Ratings							
Input Break Down Voltage	Vcc	12 V supply 5 V supply	-0.5 -0.5		13.0 5.5	V	
Storage temper.	Ts		-50		90	°C	
Control Voltage	Vc		-1 -5		5.5 5	V	Slope option "P" Slope option "N"

Electrical (4)

Frequency	F		20		100	MHz			
Frequency stability	$\Delta F/F$	vs. Temp.		± 10		ppb	See chart below		
		vs. Supply		0.2	0.3	ppb/10% Vcc			
Aging		per day		5E-10			after 30 days		
		per year, first year		1E-7			5E-8 available		
		second year		3E-8					
		per day per first year Following years		1E-10 2E-8 1E-8			Option 01 Option 01 Option 01		
Allan Deviation		.1s to 1s		1E-12		PN grade "U"			
SSB Phase Noise of 10 MHz reference. Values at actual operating frequency are higher by approximately 20LogN (N = F, MHz/10) at all frequency offsets from the carrier (achieved after 10 minutes warm-up). Example: for F = 50 MHz at 10 Hz offset of the standard version S ϕ = -126 dBc/Hz	S ϕ	1Hz 10 Hz 100 Hz 1 KHz 10 KHz 100 KHz				-110 -140 -155 -162 -170 -172	Standard version, option L		
						-112 -145 -158 -165 -170 -172	Premium version, option P		
						-115 -146 -158 -165 -170 -172	Ultimate version, option U 2*		
						-120 -148 -160 -168 -170 -173	Extraordinary version, Option E, available with slope options N or L		
			1Hz 10 Hz 100 Hz 1 KHz 10 KHz 100 KHz					-90 -120 -135 -142 -150 -152	Standard version, option L
								-92 -125 -138 -145 -150 -152	Premium version, option P

Phase Noise values are converted back to 10 MHz reference. Values at actual frequency are higher by approximately 20LogN (N = F, MHz/10) at all frequency offsets from the carrier

		1Hz 10 Hz 100 Hz 1 KHz 10 KHz 100 KHz			-95 -126 -138 -145 -150 -152		Ultimate version, option U 2*	
		1Hz 10 Hz 100 Hz 1 KHz 10 KHz 100 KHz			-100 -128 -140 -148 -150 -153		Extraordinary version, Option E, available with slope options N or L	
Retrace		After 30 minutes			±10	ppb	24 Hours off 3*	
G-sensitivity		worst direction			±1.0	ppb/G		
Input Voltage	Vcc		4.75 11.4	5.0 12.0	5.25 12.6	V	See chart below to specify	
Power consumption, Still air	P	steady state, 25°C steady state, -30°C start-up @ -30°C		1.0 1.7 2.5	1.4 3.2	W	Standard Operating Temperature*	
Spectral Purity		Sub-harmonics Spurious Harmonics/Sine		-50 -35	-80 -30	dBc		
Load		10KOhm//15pF (HCMOS/TTL), AC-coupled 50 Ohm (Sine-wave)					Output Code T Output Code S	
Warm-up time	τ	to 0.1ppm accuracy		3	5	minutes		
Output Waveform		HCMOS/TTL compatible or Sinewave						
Output Power			+5	+10		dBm	Output Code S	
Logic 1 (CMOS)	Voh		0.9 Vref			V	Output Code T	
Logic 0 (CMOS)	Vol				0.1 Vref	V	Output Code T	
Control voltage	Vc		0 -4.0 0		Vref 4.0 10	V	Slope option "P" Slope option "N" Slope option "L"	
Input impedance	Zin	At Vc pin	10			KOhm		
Modulation bandwidth	Fm		DC		1	KHz	Note 5	
Reference Voltage	Vref	Vcc = 12V Vcc = 5V		5 or 4.5 4.5		V		
Output Impedance		At Vref pin		100		Ohm		
Pull range		from nominal F	±0.3 ±0.4	±0.5 ±0.6		ppm	Slope option "P" Slope option "N"	
Deviation slope		Monotonic, positive Monotonic, negative Monotonic, positive		1.0/Vref -0.13 -0.12		ppm/V	Slope option "P" Slope option "N" Slope option "L"	
Setability	Vc0	@25°C, Fnom. No internal bias for slope option "L"		Vref/2 ± 0.5 0 ± 0.5 5 ± 0.5		V	Slope option "P" 3* Slope option "N" Slope option "L"	

Notes:

- *. For highest operating temperature higher than 70°C the power consumption will be higher (about 20% for 85°C). Values listed are for test in still air environment, the values will go up while testing in the temperature chamber.
- 2*. It is recommended to specify Slope option "N" for Ultimate Phase noise performance. For recommended phase noise test, contact factory. It's assumed that phase noise test is performed under static conditions (no vibration), in still air, and care is taken for minimizing EMI.
- 3*. Longer storage time, especially at low temperatures, may affect both retrace and setability parameters. It may require few days on power for re-stabilization.
- 4. All parameters, unless otherwise specified, are at nominal conditions, ie: T=25°C, Nominal Vcc & Nominal Load.
- 5. Older and stock units may have MBW of 150 Hz Max.

Environmental and Mechanical

Operating temp. range	-30°C to 70°C Standard, Other options – see chart below
Mechanical Shock	Per MIL-STD-202, 30G, 11ms
Vibration	Per MIL-STD-202, 5G to 2000 Hz
Soldering Conditions	260°C for 10s Max leads only

Electrical Connections

Pin Out	Pin #1- Vc ; Pin#2 – Vref; Pin #3 – Vcc; Pin #4- Output ; Pin #5- GND;
----------------	--

Creating a Part Number

Q - C X M X X YZ XX - X - X - XX - X FREQ
OCXO | **Multiplied** | **Environmental**

Conventional Power

Package Code
 E 5 pin 36x27mm
 A for adapter

Supply Voltage

Code	Specification
0	5V ± 5%
F	12V± 5%

Output

Code	Specification
T	CMOS/TTL
S	Sinewave

Temperature Stability

Code	Specification
17	1x10 ⁻⁷
58	5x10 ⁻⁸
28	2x10 ⁻⁸
18	1x10 ⁻⁸
59	5x10 ⁻⁹
YZ	Yx10 ^{-Z}

Temperature Range

Code	In 5°C steps **
First letter	Lowest temperature from A = -40°C
Second letter	Highest temperature to Z = 85°C
Examples	
AZ	-40°C to 85°C
GU	-10°C to 60°C
EW	-20°C to 70°C

Environmental

Code	Specification
L	Contains a level of lead that is in excess of RoHS directive and is not designed for reflow
R	RoHS compliant, not designed for reflow

Aging

Insert Value per day times 1E-10	
Examples	
5	5E-10 = 0.5 ppb/day
10	1E-9 = 1 ppb/day
01	1E-10 = 0.1 ppb/day

Phase Noise (See Table)

Code	Specification
L	Standard
P	Premium
U	Ultimate
E	Extraordinary

Deviation slope

Code	Specification
P	Positive, 0 to Vref
N	Negative, -4 to 4V
L	Positive, 0 to 10V

Not all combinations are available. Consult Factory.



**FREQUENCY
 CONTROLS, INC.**

357 Beloit Street, Burlington, WI 53105 U.S.A. Phone 262/763-3591 FAX 262/763-2881

Email: nelsales@nelfc.com www.nelfc.com

****Temperature Code Table**

Letter	Temp °C	Letter	Temp °C	Letter	Temp °C	Letter	Temp °C	Letter	Temp °C	Letter	Temp °C
A	-40	F	-15	K	10	P	35	U	60	Z	85
B	-35	G	-10	L	15	Q	40	V	65		
C	-30	H	-5	M	20	R	45	W	70		
D	-25	I	0	N	25	S	50	X	75		
E	-20	J	5	O	30	T	55	Y	80		

Optional adapter for 2"x 2" compatibility:

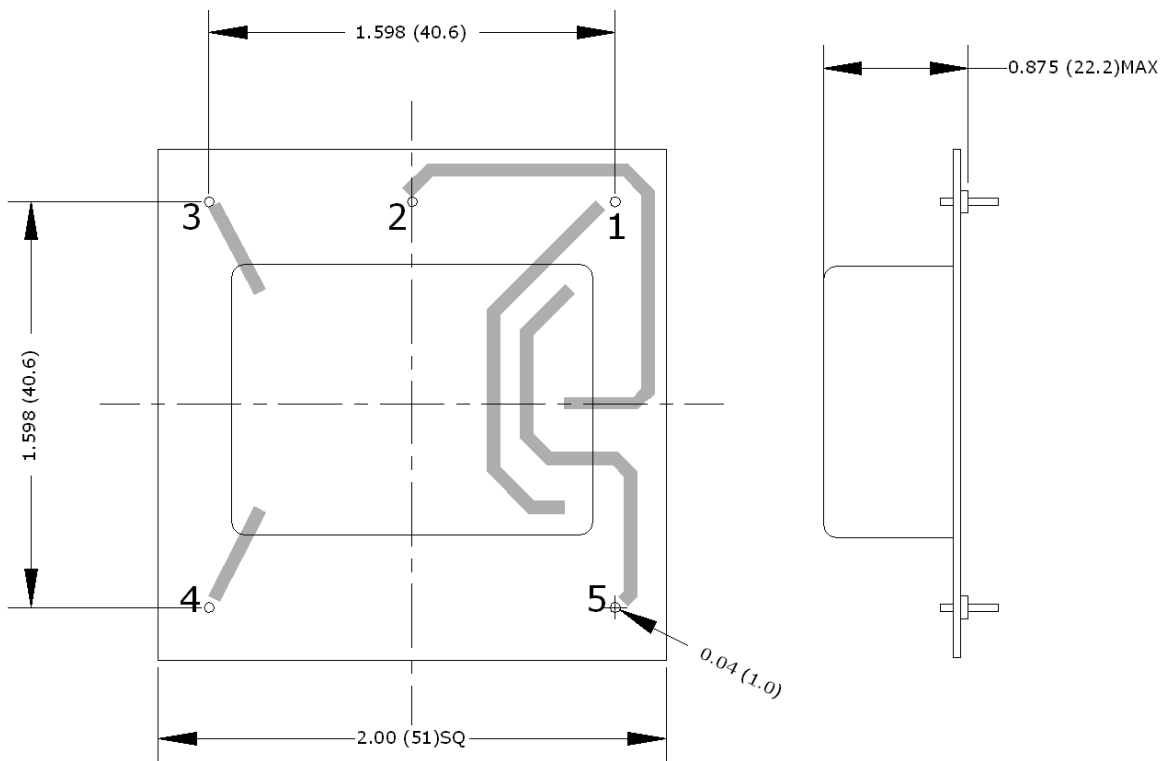

Adapter Pin Out	Pin #1-Vc ; Pin#2 – Vref; Pin #3 – Output; Pin #4- GND ; Pin #5- Vcc;
------------------------	---